



MLL -F-360 /1~50mW



**LD PUMPED ALL-SOLID-STATE
LOW NOISE UV LASER
AT 360 nm**

All solid state low noise UV laser at 360 nm is made features of TEM₀₀, long lifetime and easy operating, which is widely used in measurement, spectrum analysis as the substitute for He-Ne lasers.



SPECIFICATIONS

Central wavelength (nm)	360±1
Operating mode	CW
Output power (mW)	>1, 2, 3, ... , 50
Power stability (rms, over 4 hours)	<1%, <3%, <5%
Transverse mode	TEM ₀₀
M ² factor	<2.0
Beam diameter at the aperture (1/e ² , mm)	~1.5
Beam divergence, full angle (mrad)	<1.0
Polarization ratio	>50:1, >100:1, optional Horizontal ±5 degree (Vertical Optional)
Warm-up time (minutes)	<10
Beam height from base plate (mm)	45
Operating temperature (°C)	10~35
Power supply (90-264VAC)	PSU-H-FDA
Expected lifetime (hours)	5000
Warranty	1 year



MLL-F-360

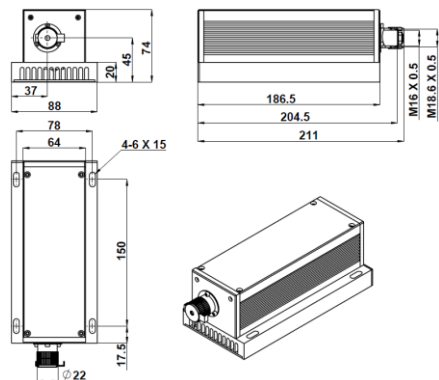

211 (L) × 88 (W) × 74 (H) mm³, 1.6 kg

PSU-H-FDA

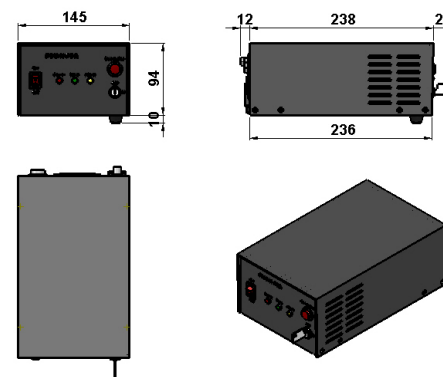

236 (L) × 145 (W) × 104 (H) mm³, 2.3 kg